

Categorical Semantics of Cyber-Physical Systems

Christina Vasilakopoulou

University of Patras, Greece



HFRI.
Hellenic Foundation for
Research & Innovation

TallCat seminar, Tallinn University of Technology

5 November 2020

Systems Theory and Design

Idea: provide categorical framework for modeling and analysis of systems

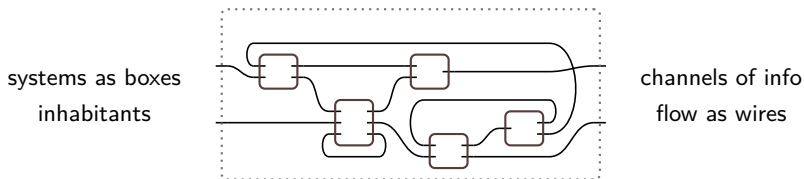

Analyse the composite system using the analyses of the particular system components and their specific wired interconnection.

- ▶ System architecture and behavior in single model. . .

Outline

1. The monoidal category of labelled boxes and wiring diagrams
2. Systems as algebras for wiring diagrams
3. Interval sheaves
4. Abstract machines

Labelled boxes and wiring diagrams

There is a category **WD** that consists of the following:

- objects are pairs of sets $X = (X_{\text{in}}, X_{\text{out}})$

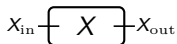

think of X as a placeholder for systems,
with input&output info values in $X_{\text{in}}, X_{\text{out}}$

Example: an object $(\mathbb{R} \times \mathbb{N}, \{\top, \perp\})$ is an empty box

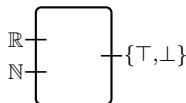

A process that can later populate the box is a function

$$f(r, n) = \begin{cases} \top & \text{if } r = n \\ \perp & \text{if } r \neq n \end{cases}$$

- morphisms $(X_{\text{in}}, X_{\text{out}}) \rightarrow (Y_{\text{in}}, Y_{\text{out}})$ are pairs of 'special' functions
 $(X_{\text{out}} \times Y_{\text{in}} \xrightarrow{\phi_{\text{in}}} X_{\text{in}}, X_{\text{out}} \xrightarrow{\phi_{\text{out}}} Y_{\text{out}})$

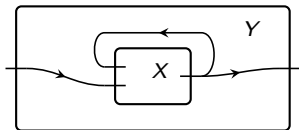

think of $\phi_{\text{in/out}}$ expressing the flow of info through the ports

Example: the morphism $(\mathbb{R}^2 \times \mathbb{N}, \{\top, \perp\} \times \mathbb{N}) \rightarrow (\mathbb{R}, \{\top, \perp\})$ as in

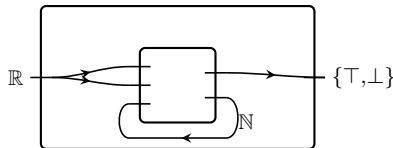

is described by the two functions

$$\left\{ \begin{array}{l} \phi_{\text{in}}: \underbrace{\{\top, \perp\} \times \mathbb{N}}_{X_{\text{out}}} \times \underbrace{\mathbb{R}}_{Y_{\text{in}}} \rightarrow \underbrace{\mathbb{R}^2 \times \mathbb{N}}_{X_{\text{in}}} \quad \text{by } \phi_{\text{in}}(x, n, r) = (r, r, n) \\ \phi_{\text{out}}: \underbrace{\{\top, \perp\} \times \mathbb{N}}_{X_{\text{out}}} \rightarrow \underbrace{\{\top, \perp\}}_{Y_{\text{out}}} \quad \text{by } \phi_{\text{out}}(x, n) = x \end{array} \right.$$

Monoidal structure

- tensor product $X \otimes Y = (X_{\text{in}} \times Y_{\text{in}}, X_{\text{out}} \times Y_{\text{out}})$

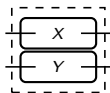

think of parallel execution of processes

Example: for three boxes $(\mathbb{R} \times \mathbb{N}, \{T, \perp\})$, (\mathbb{C}, \mathbb{R}) and $(\mathbb{C}, \mathbb{C}^3)$, their tensor is $(\mathbb{R} \times \mathbb{N} \times \mathbb{C}^2, \{T, \perp\} \times \mathbb{R} \times \mathbb{C}^3)$

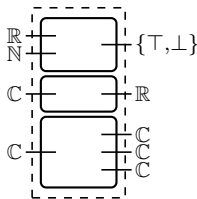

With appropriate composition law and identities, all axioms hold.

The category **WD** of labeled boxes and wiring diagrams is a monoidal category.

Any wiring interconnection can be expressed as a morphism in **WD**!

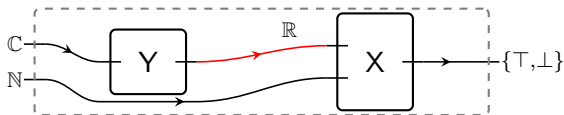

can be equivalently rearranged into

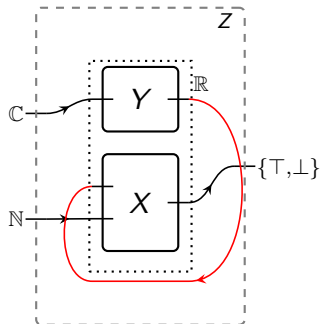

$$\phi_{\text{in}}: \mathbb{R} \times \{T, \perp\} \times \mathbb{C} \times \mathbb{N} \rightarrow \mathbb{C} \times \mathbb{R} \times \mathbb{N},$$

$$(r, x, c, n) \mapsto (c, r, n)$$

$$\phi_{\text{out}}: \mathbb{R} \times \{T, \perp\} \rightarrow \{T, \perp\},$$

$$(r, x) \mapsto x$$

All functions are made up from projections, duplications and switches:
Set could be replaced by *any* typing category \mathcal{C} with finite products.

The operad of wiring diagrams

Before, first 'aligned' all boxes to form their tensor and then computed the wiring; this relates to the *underlying operad* of any monoidal category.

A *colored operad* or *multicategory* \mathcal{P} consists of

- a set of objects (colors)
- for each $(n + 1)$ -tuple of objects, a set of n -ary operations $\mathcal{P}(c_1, \dots, c_n; c)$
- an identity operation $\text{id}_c \in \mathcal{P}(c; c)$
- a composition formula for nesting of operations

subject to associativity and unitality axioms.

► Every monoidal category \mathcal{V} gives rise to an operad $\mathcal{O}(\mathcal{V})$ with same objects and n -ary operations $\mathcal{O}(\mathcal{V})(c_1, \dots, c_n; c) := \mathcal{V}(c_1 \otimes \dots \otimes c_n, c)$.

★ Pictures are nicer in the operad $\mathcal{O}(\mathbf{WD})$ than \mathbf{WD} !

Lax monoidal functors $F: (\mathcal{V}, \otimes, I) \rightarrow (\mathbf{Cat}, \times, \mathbf{1})$ are called \mathcal{V} -algebras.

Fully faithful underlying operad functor $\mathbf{SMonCat}_\ell \xrightarrow{\mathcal{O}} \mathbf{SOpd}$ induces

$$\mathcal{V}\text{-Alg} \cong \mathbf{SOpd}(\mathcal{OV}, \mathcal{OCat}) =: (\mathcal{OV})\text{-Alg}.$$

$$\begin{array}{ccc}
 F: \mathbf{WD} & \longrightarrow & \mathbf{Cat} \\
 X=(X_{\text{in}}, X_{\text{out}}) & \longmapsto & FX \quad \text{subsystems category} \\
 \phi \downarrow & & \downarrow F\phi \quad \text{composite system functor} \\
 Y=(Y_{\text{in}}, Y_{\text{out}}) & \longmapsto & FY
 \end{array}$$

gives *semantics* to boxes, *composite operation* to wiring diagrams and *parallelizing operation* to subsystems via $FX \times FY \rightarrow F(X \otimes Y)$

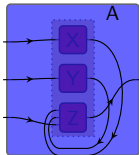

Algebra of contracts

There is a lax monoidal functor $\mathbf{Cntr}: \mathbf{WD} \rightarrow \mathbf{Cat}$ that

- to each box $X_{\text{in}} \boxed{X} X_{\text{out}}$ assigns category of *contracts*, i.e. relations

$$R \subseteq X_{\text{in}} \times X_{\text{out}}$$

- to each wiring diagram  assigns formula

$$\begin{array}{ccc}
 P & \xrightarrow{\quad} & R \\
 \downarrow \lrcorner & & \downarrow \\
 Y_{\text{in}} \times X_{\text{out}} & \xrightarrow{(\phi_{\text{in}}, \pi_2)} & X_{\text{in}} \times X_{\text{out}} \\
 \downarrow 1 \times \phi_{\text{out}} & & \\
 Y_{\text{in}} \times Y_{\text{out}} & &
 \end{array}$$

S

that, given contracts on subsystems, produces contract on composite.

- For each $R_X \subseteq X_{\text{in}} \times X_{\text{out}}$ and $R_Y \subseteq Y_{\text{in}} \times Y_{\text{out}}$ assigns contract

$$R_X \times R_Y \subseteq X_{\text{in}} \times X_{\text{out}} \times Y_{\text{in}} \times Y_{\text{out}} \cong X_{\text{in}} \times Y_{\text{in}} \times X_{\text{out}} \times Y_{\text{out}}$$

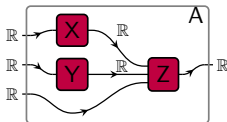

$$R_X = [4, 5] \times [4, 5], \quad R_Y = [8, 9] \times [8, 9]$$

$$R_Z = [3, 5] \times [7, 9] \times \mathbb{R} \times [0, 1] \text{ produce}$$

$$R_A = [4, 5] \times [8, 9] \times \mathbb{R} \times [0, 1]$$

Algebra of discrete dynamical systems

Fix two sets $X_{\text{in}}, X_{\text{out}}$. A DDS (or *Moore machine*) consists of a set of states S along with two functions, $\text{upd}: X_{\text{in}} \times S \rightarrow S$ that updates the state given some input, and $\text{rdt}: S \rightarrow X_{\text{out}}$ that readouts an output value.

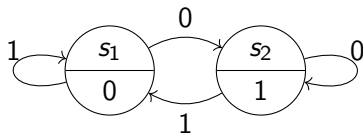

$(S = \{s_1, s_2\}, \text{upd}, \text{rdt})$
is the NOT machine

Model discrete systems as a **WD**-algebra:

WD \longrightarrow **Cat**

$X = (X_{\text{in}}, X_{\text{out}}) \longmapsto \text{DDS}(X_{\text{in}}, X_{\text{out}})$

$\phi \downarrow$

$Y = (Y_{\text{in}}, Y_{\text{out}}) \longmapsto \text{DDS}(Y_{\text{in}}, Y_{\text{out}})$

$\downarrow \text{DDS}(\phi)$

via $(S, f^{\text{upd}}, f^{\text{rdt}}) \mapsto (S, g^{\text{upd}}, g^{\text{rdt}})$,

$g^{\text{upd}}(y, s) = f^{\text{upd}}(\phi_{\text{in}}(y, f^{\text{rdt}}(s)), s)$

$g^{\text{rdt}}(s) = \phi_{\text{out}}(f^{\text{rdt}}(s))$

Systems theory in categorical terms

- ▶ The contracts algebra corresponds to the *requirements* part of systems analysis and design, which is fundamental for safety and control.
- ▶ Other **WD**-algebras, like the discrete or continuous dynamical systems, correspond to the *behavior* part, i.e. the physical specification of the process that inhabits the boxes.
- ▶ The categorical syntax of labeled boxes and wirings corresponds to the *architecture* part. Importantly, choosing subcomponents X_1, \dots, X_n of a system Y as well as the way they are wired together (share information) is choosing a morphism $\phi: X_1 \otimes \dots \otimes X_n \rightarrow Y$ in **WD**, i.e. an object in the *slice category* **WD**/ Y

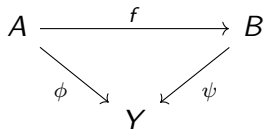

architectural choices and their relation

Case study: UAV

★ Using the sub-algebra of *linear time-invariant* systems, can analyze the behavior of an unmanned aerial vehicle and also decompose it to a system architecture and constraint it via contracts.

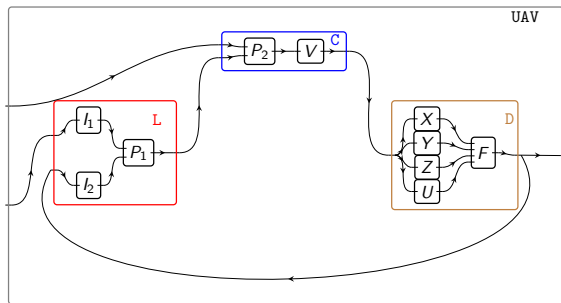

$$I_1 \otimes I_2 \otimes P_1 \otimes P_2 \otimes V \otimes X \otimes Y \otimes Z \otimes U \otimes F \xrightarrow{f \otimes g \otimes h} L \otimes C \otimes D \xrightarrow{k} UAV$$

Modeling Time: Categories of intervals

$\mathbb{R}_{\geq 0}$ positive reals, $\text{Tr}_p : \mathbb{R}_{\geq 0} \rightarrow \mathbb{R}_{\geq 0}$ translation-by- p .

► Category **Int** of *continuous intervals* has objects $\mathbb{R}_{\geq 0}$, morphisms $\text{Int}(\ell, \ell') = \{\text{Tr}_p \mid p \in \mathbb{R}_{\geq 0} \text{ and } p \leq \ell' - \ell\}$; equivalently via image

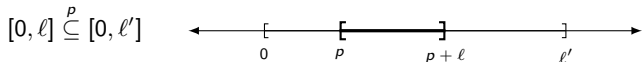

► Category **Int_N** of *discrete intervals*, $\text{ob} = \mathbb{N}$, $n \xrightarrow{\text{Tr}_p} n'$ by $p \in \mathbb{N}$.

★ Int-presheaves: for $A: \mathbf{Int}^{\text{op}} \rightarrow \mathbf{Set}$, view section $x \in A(\ell')$ & restriction $A(\text{Tr}_p)(x)$

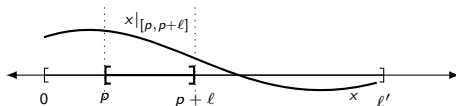

Sheaves on intervals

For $\ell \in \mathbf{Int}$ and $0 \leq p \leq \ell$, the pairs $p \xrightarrow{[0,p]} \ell$, $(\ell-p) \xrightarrow{[p,\ell]} \ell$ form a cover for ℓ . These generate a coverage for \mathbf{Int} ; similarly for \mathbf{Int}_N .

* $\widetilde{\mathbf{Int}}$ and $\widetilde{\mathbf{Int}}_N$ are the toposes of *continuous* and *discrete interval sheaves*, i.e. $\mathbf{Int}_{(N)}$ -presheaves whose compatible sections glue.

Idea: $\widetilde{\mathbf{Int}}_{(N)}$ -labeled boxes have ports carrying very general time-based signals, expressed as sheaves of 'all possible behaviors'.

Examples

- $\widetilde{\mathbf{Int}}_N \simeq \mathbf{Grph}$, so every graph gives a discrete interval sheaf
- $\mathbf{L}: \mathbf{Set} \rightarrow \widetilde{\mathbf{Int}}_N$ by $\mathbf{L}(X)(n) = X^{n+1}$, non-empty X -lists sheaf
- $\mathbf{F}: \mathbf{Set} \rightarrow \widetilde{\mathbf{Int}}$ by $\mathbf{F}(X)(\ell) = \{f: [0, \ell] \rightarrow X\}$, sheaf of functions
- $\mathbf{Ext}_\epsilon: \widetilde{\mathbf{Int}} \rightarrow \widetilde{\mathbf{Int}}$ by $\mathbf{Ext}_\epsilon(A)(\ell) = A(\ell + \epsilon)$, ϵ -extension sheaf

Abstract machines

Purpose: define abstract systems in terms of **Int**-sheaves; perceive known dynamical systems as special cases; coherently interconnect arbitrary systems and study their behavior on common ground.

- A *continuous machine* with input & output A & $B \in \widetilde{\mathbf{Int}}$ is

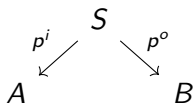

S - state sheaf

p^i - input sheaf map

p^o - output sheaf map

$\text{Mch}(A, B) = \widetilde{\mathbf{Int}}_{/A \times B}$ the topos of continuous (A, B) -machines.

- For $A, B \in \widetilde{\mathbf{Int}}_N$, *discrete machines* $\text{Mch}_N(A, B) = \widetilde{\mathbf{Int}}_N /_{A \times B}$.

Continuous machines form a $\mathbf{WD}_{\text{Int}}^{\sim}$ -algebra

Functor $\text{Mch}: \mathbf{WD}_{\text{Int}}^{\sim} \rightarrow \mathbf{Cat}$ by $(X_{\text{in}}, X_{\text{out}}) \mapsto \text{Mch}(X_{\text{in}}, X_{\text{out}})$ and

$$\begin{array}{ccc}
 \begin{array}{c} S \\ \downarrow (p^i, p^o) \\ X_{\text{in}} \times X_{\text{out}} \end{array} & \xrightarrow{\text{Mch}(\phi)} & \begin{array}{ccc} T & \xrightarrow{\quad} & S \\ \downarrow (q^i, q^o) & \lrcorner & \downarrow (p^i, p^o) \\ Y_{\text{in}} \times X_{\text{out}} & \xrightarrow{(\phi_{\text{in}}, \pi_2)} & X_{\text{in}} \times X_{\text{out}} \\ \downarrow 1 \times \phi_{\text{out}} & & \downarrow \\ Y_{\text{in}} \times Y_{\text{out}} & & \end{array}
 \end{array}$$

In fact, for any \mathcal{C} with pullbacks, this process is

$$\mathcal{C}/X_{\text{in}} \times X_{\text{out}} \xrightarrow{(\phi_{\text{in}}, \pi_2)^*} \mathcal{C}/Y_{\text{in}} \times X_{\text{out}} \xrightarrow{(1 \times \phi_{\text{out}})_!} \mathcal{C}/Y_{\text{in}} \times Y_{\text{out}}.$$

Finally, lax monoidal structure by taking products of spans:

$$(S \xrightarrow{(p^i, p^o)} X_{\text{in}} \times X_{\text{out}}, T \xrightarrow{(q^i, q^o)} Z_{\text{in}} \times Z_{\text{out}}) \mapsto (p^i \times q^i, p^o \times q^o)$$

Total and deterministic machines

Characteristics of interest: for initial state and input, the machine

- uniquely evolves or 'stays idle' \rightsquigarrow determinism
- always evolves \rightsquigarrow totality

► Continuous machines $A \left[S \right] B$ are neither in general:

Starting in state germ s_0 , for input a over ℓ -interval, there may or may not be s_0 -extension

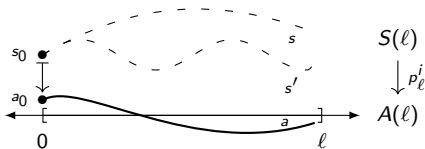

★ A *total* machine would have at least one extension, whereas a *deterministic* machine would have maximum one extension.

★ There exist subalgebras of $\text{Mch}_{(N)} : \mathbf{WD}_{\text{Int}} \rightarrow \mathbf{Cat}$ of total and deterministic machines, by imposing conditions on p^i and q^i .

▶ There are algebra maps from discrete dynamical systems

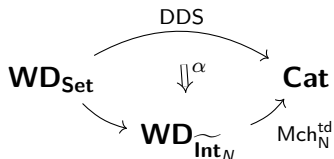

and from continuous dynamical systems

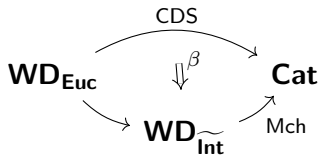

Algebra maps 'translate' between various processes; can then interconnect arbitrary systems & study them on common ground.

Thank you for your attention!

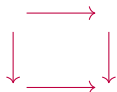

- *Bakirtzis, Fleming, Vasilakopoulou*, “Categorical Semantics of Cyber-Physical Systems Modeling”, arXiv:2010.08003, 2020
- *Schultz, Spivak, Vasilakopoulou*, “Dynamical Systems and Sheaves”, Applied Categorical Structures, 2020
- *Vagner, Spivak, Lerman*, “Algebras of open dynamical systems on the operad of wiring diagrams”, Theory and Applications of Categories, 2015